

EVALUATION UNIT

INNOVIZONE

Automotive-Grade LiDAR

InnovizOne is a high-performance, automotive-grade, solid-state LiDAR sensor with unsurpassed 3D perception performance that is targeted at the mass-production of Level 2.5 to Level 5 autonomous vehicles.

The rugged, reliable, functionally safe, and cost-effective LiDAR is lightweight, low-power, and resilient to sunlight and weather conditions. The sensor delivers a dense, highly accurate, 3D point cloud with unrivaled angular resolution at a high frame rate for distances up to 250 meters.

InnovizOne's firmware is delivered with pre-configured functionality including: scanning configuration with Regions of Interest (ROI); vertical FOV; pixel summation structure; frame rate; and number of reflections. The Eagle configuration is ideal for highway applications that require higher resolution and longer detection range in the ROI. The Falcon configuration is recommended for applications that require a wide, uniform FOV.

Innoviz's complementary perception software converts the LiDAR's raw point cloud data into high quality perception outputs for outstanding object detection, classification, and tracking; LiDAR calibration; and pixel collision classification (frame-by-frame detection and classification of pixels as possible obstacles within the drivable and non-drivable area.)

KEY PERFORMANCE METRICS

1.2m-250m
Detection Range

0.1°x0.1°
Angular Resolution (HxV)

115°x25°
Maximum Field of View (HxV)

10 or 15FPS
Pre-Configured Frame Rate

ASIL B(D)
ISO 26262-Compliant

IP6K6K, IP6K9K & IP6K7
Ingress Protection

45x111.4x97.9mm
Dimensions (HxWxD)

-15°C to +85°C
Operating Temperature

UNIQUE FEATURES



Regions of Interest or
Uniform Field of View



Multiple Reflections



No Gaps
Between Pixels



Equally Distributed VFOV



Resilient to Sunlight and
Weather Conditions

MARKET APPLICATIONS



Consumer
Vehicles



Robotaxis,
Shuttles



Trucking



Heavy
Machinery



Construction



Logistics



Smart
Cities

SPECIFICATIONS

SYSTEM

	Eagle Configuration	Falcon Configuration
Field of View (HxV)	115°x15°	115°x25°
Region of Interest (HxV)	20°x8° ROI in the center	N/A
Frame Rate	15FPS	10FPS
Scanned Lines within FOV	160	256
Maximum Range	250m	200m
Angular Resolution (HxV)	Native pixels: 0.1°x0.1° Summation pixels: 0.2°x0.2°	
Laser Product Class	Class 1, Eye-safe (IEC-60825-1)	
Wavelength	905nm	

OPTICAL PERFORMANCE

			Eagle Configuration		Falcon Configuration	
			@10% Reflectivity	@50% Reflectivity	@10% Reflectivity	@50% Reflectivity
Long-Range Detection ¹	Inside ROI	0.1°x0.1° Resolution (Native pixels)	100m	150m	N/A	N/A
		0.2°x0.2° Resolution (Summation pixels ²)	125m	190m	N/A	N/A
	Outside ROI	0.1°x0.1° Resolution (Native pixels)	55m	95m	85m	130m
		0.2°x0.2° Resolution (Summation pixels ²)	70m	125m	110m	165m
Long-Range Resolution ³	Native pixels		1cm			
	Summation pixels ²		30cm			
Long-Range Accuracy (Bias) ⁴			Maximum 7cm or 0.2% of ground truth			
Range Precision ⁴			Maximum 7cm or 0.2% of ground truth			
Angular Resolution Accuracy			0.05°@1σ (in nominal conditions ³)			
Short-Range Detection			1.2m-3.6m			
Short-Range Angular Resolution (HxV)			0.1°x0.8°			
Short-Range Resolution ³			30cm			
Short-Range Accuracy (Bias)			30cm			

NOTES:

¹ 10% Lambertian target @20Klux. True Positives = 90% per pixel and False Alarm Rate = 5% per pixel based on the above configuration for long-range detection. False Positives are configurable from 0.01% to more than 10%.

² Pixel Summation Mode (PSM) increases detection range.

³ 25°C ambient temperature; lighting as defined in the specifications; defined scanning configuration; native VFOV setting; 0° LiDAR roll/pitch; clear weather; no blockage on window; LiDAR is operating in Normal power mode.

⁴ Based on a normal target with Lambertian reflectivity up to 100%.



OUTPUTS

	Eagle Configuration		Falcon Configuration	
	1 Reflection	2 Reflections (Outside ROI only)	1 Reflection	2 Reflections
Points returned per second for full FOV (native pixels)	2.8M	5.6M	3M	6M
Points returned per second for full FOV with one reflection (summation pixels)	720K		768K	
Point Cloud Attributes	Per reflection: Distance, reflectivity, and confidence Per-pixel: Timestamp, number of reflections, blockage indication, and angular coordinates of pixel Per frame: Window blockage detection (by region); frame sequence number			
Point Cloud Reflections	Native pixels: up to 2 Summation pixels: 1			
Pixel Latency	<10msec (from first laser pulse of a pixel until the pixel detection is sent to the MIPI interface)			
Time Stamp	10 μsec accuracy for every pixel (with GPS input)			

INTERFACES

Data	MIPI CSI-2 interface (1.5Gbps data rate) aggregated over a two-wire GMSL high-speed LVDS interface
Command and Control	SPI slave interface and GPIO signals aggregated over two-wire GMSL high-speed LVDS interface; Enable~ pin over power connector
Time Synchronization	PPS using \$GPRMC time message inputs over SPI interface and GPIO signals

MECHANICAL/ELECTRICAL

Power Consumption	17W (typical)	
Operating Voltage	6.5V	
Dimensions	45x111.4x97.9mm (HxWxD)	
Weight	515g	
Connectors	Data	Rosenberger H-MTD® (P/N E6S147-40MT5-A)
	Power	Rosenberger MQS (P/N MPS104-40MZ1-A)
Temperature	Operating	-15° to +85°C with airflow/cooling solution (depending on configuration, mounting position and environment)
	Storage	-40° to +105°C
Lifetime	15 years or 300,000km	
Total Operating Hours	8,000	

REGULATORY COMPLIANCE

	Standard
Component-Level Safety and Reliability	ASIC: AEC Q100 (Grade 2)
	Laser: AEC Q102
	Detector: AECQ
	MEMS: AECQ and BMW GS 950324-3-1
System-Level Safety, Reliability and Cybersecurity	IEC60825-1 "Safety of laser products"
	ISO 26262 ASIL B(D) "Road vehicles – Functional safety"
	ISO 21434 "Road vehicles - Cybersecurity engineering"
Electromagnetic Compatibility (EMC)	BMW GS 95002 (based on CISPR 25)
Environmental	DIN/EN/IEC 60068-2; ISO 16750; ISO 20653 (IP6K6K, IP6K9K & IP6K7); EN 61326-1; EN 62368-1; DIN 75220; Directive 2011/65/EU (RoHS 2); Directive (EU) 2015/863 (RoHS Appendix); REACH (EC 1907/2006-Art. 33)

- InnovizOne includes proprietary hardware and software components that maximize its performance.
- The LiDAR's GMSL data output aggregates various communication channels and protocols.
- Innoviz's LiDAR Manager software runs on the OEM's Electronic Control Unit (ECU) and enables command and control of the LiDAR.
- Innoviz's optional perception software ensures optimal processing of the LiDAR's raw point cloud data output; delivers outstanding object detection, classification, and tracking; performs pixel collision classification (see definition on cover page); provides window blockage status; and calibrates the LiDAR.

SYSTEM ARCHITECTURE

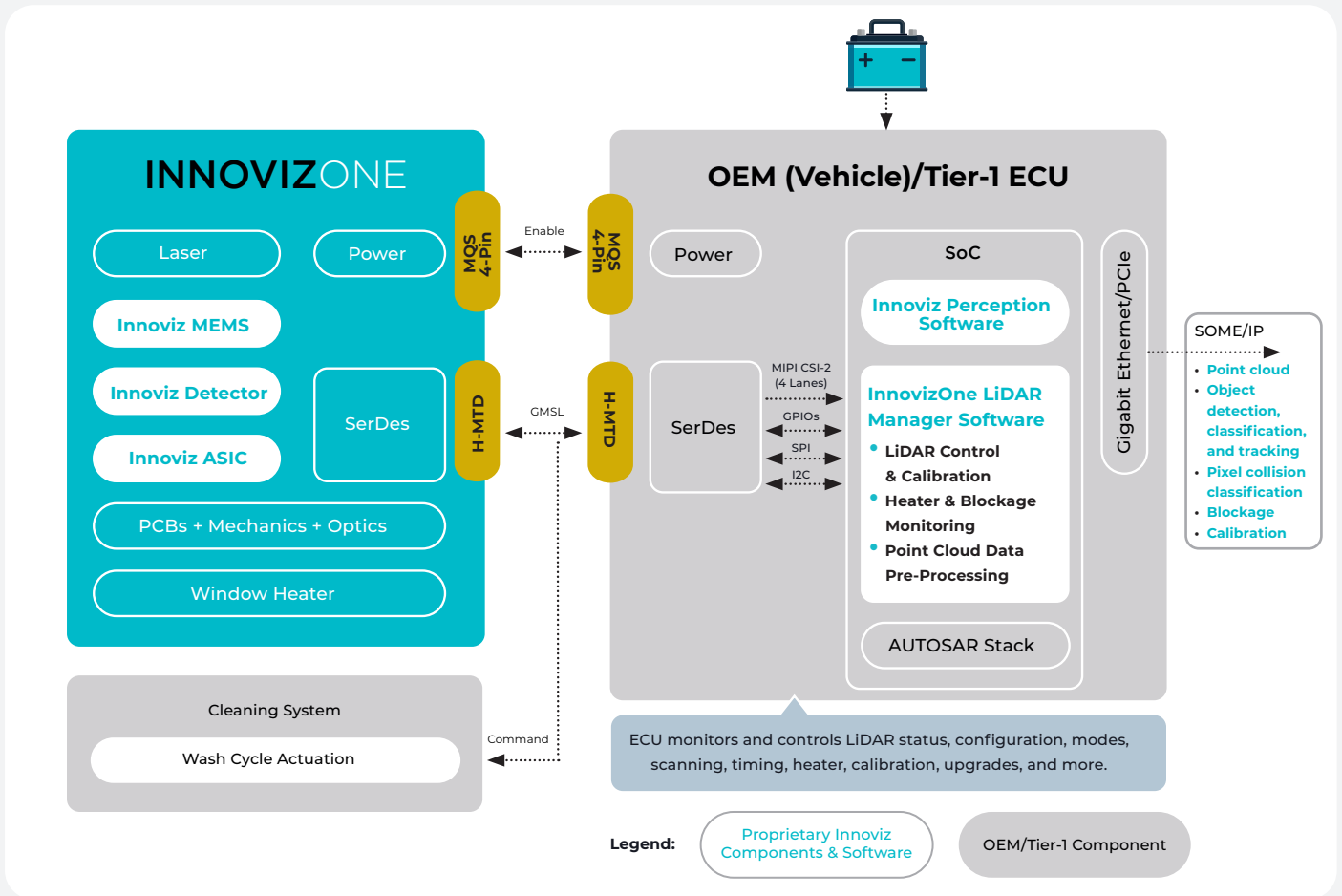

InnovizOne data packets must be converted to the format used by the OEM's perception software. This packet format conversion can be done in an external component or directly in the OEM's ECU.

INNOVIZONE CONNECTED TO ECU VIA COMPUTE MODULE

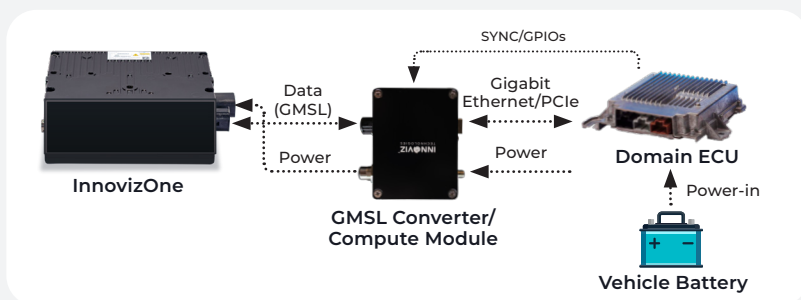

INNOVIZONE DIRECTLY CONNECTED TO ECU

